

# INSTRUCTIONS

## Specifications:

<b>Image Sensor:</b>	Sony 1/3" Hi-Res Super HAD
<b>Picture Elements:</b>	NTSC: 768x494
<b>Resolution:</b>	550 lines
<b>S/N Ratio:</b>	More than 48 dB
<b>Min Illumination:</b>	0.4 LUX @ F2.0
<b>Electronic Shutter:</b>	1/60s - 1/100,000s, ON/OFF Switch-able
<b>Iris Control:</b>	Built-in DC Drive Iris Control
<b>Flickerless Mode:</b>	1/60s ON/OFF switchable
<b>Gain Control:</b>	High/Low switchable
<b>Auto White Balance:</b>	Color Temperature: 2500K-9500K
<b>Back Light Comp.:</b>	ON/OFF switchable
<b>Gamma Characteristic:</b>	0.45
<b>Camera Lens:</b>	Vari-Focal with DC Drive Iris Lens
<b>Focal Length &amp; App. Ratio:</b>	3.7mm-12mm, F1.6-3.0
<b>Angle of View:</b>	Wide: 71.6°x55.8°, Tele: 23.8°x17.9°
<b>Sync. System:</b>	Internal, Negative sync.
<b>Power Requirements:</b>	12VDC
<b>Power Consumption:</b>	195 mA
<b>Video Output:</b>	1 Vp-p @ 75 ohms
<b>Operating Temp:</b>	-10°C to 50°C (14°F to 122°F)

Specifications subject to change without notice.

## CHANNEL VISION Limited Warranty

Channel Vision Technology will repair or replace any defect in material or workmanship which occurs during normal use of this product with new or rebuilt parts, free of charge in the USA, for two years from the date of original purchase. This is a no hassle warranty with no mail in warranty card needed. This warranty does not cover damages in shipment, failures caused by other products not supplied by Channel Vision Technology, or failures due to accident, misuse, abuse, or alteration of the equipment. This warranty is extended only to the original purchaser, and a purchase receipt, invoice, or other proof of original purchase date will be required before warranty repairs are provided.

Mail in service can be obtained during the warranty period by calling (800) 840-0288 toll free. A Return Authorization number must be obtained in advance and can be marked on the outside of the shipping carton.

This warranty gives you specific legal rights and you may have other rights (which vary from state to state). If a problem with this product develops during or after the warranty period, please contact Channel Vision Technology, your dealer or any factory-authorized service center.



## 6117 Vandal-Proof Color Dome Camera

# Model 6117

The **6117** is a vandal-proof color dome camera. Its extremely rugged construction makes it ideal for CCTV installations where the camera will be subjected to physical abuse. Typical applications included factories, warehouses, and other industrial buildings.

## Features:

- High quality 1/3" Sony Hi-Res Super HAD CCD sensor
- 550 TV lines of resolution
- Digital Signal Processor (DSP) chip-set provides image control
- High sensitivity, low smear, high anti-blooming and high S/N ratio
- Automatic Gain Control (AGC) and Auto White Balance (AWB)
- 3-Axis mechanism for easy rotation and adjustment

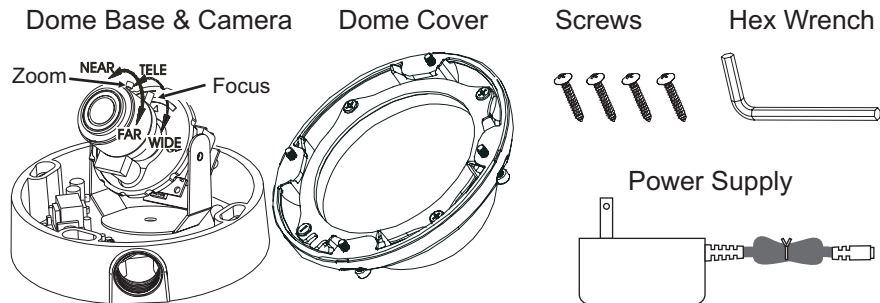

## Adjusting the 3-Axis Mount

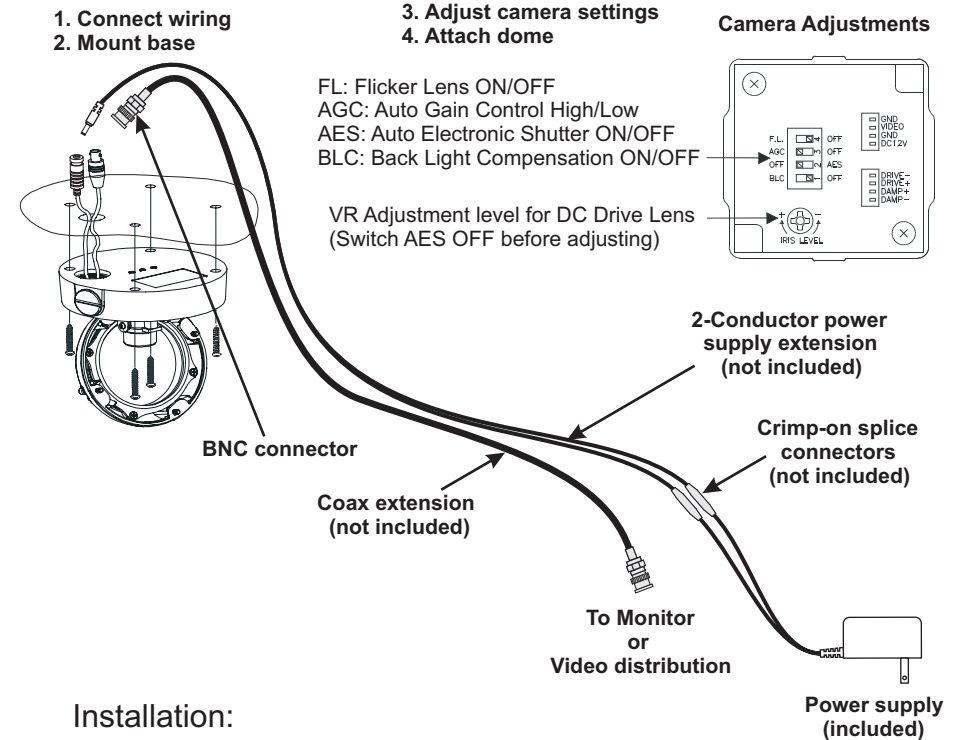
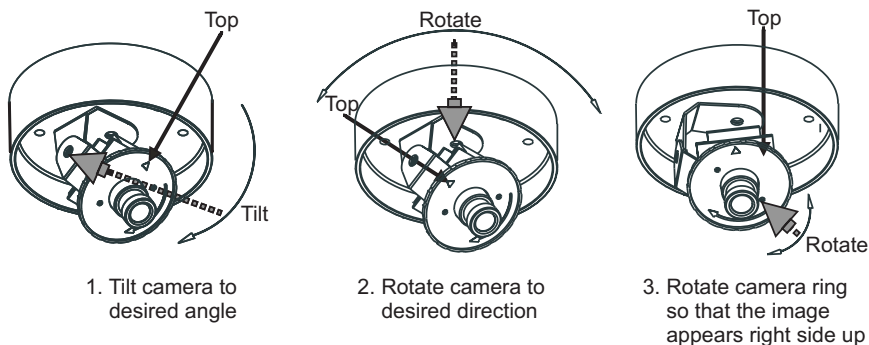

## Installation:

- Using the wrench, loosen the 4 screws securing the dome cover to the base.
- Drill a hole in the wall or ceiling for wiring (see diagram).
- If necessary, attach the camera's video output to a coax extension that is long enough to reach your monitor or video distribution equipment.
- If necessary, cut the connector off of the end of the power supply and splice in an extension using crimp-on connectors.
- Mount the base with the provided screws.
- Move the camera body to adjust the view and make electronic adjustments using the dip switches.
- Re-attach the dome cover by tightening the four screws with the provided wrench.