

INSTRUCTIONS

Specifications:

Image Sensor:	Sony 1/3" Super HAD
Picture Elements:	NTSC: 510x492
Resolution:	470 lines
S/N Ratio:	More than 48 dB
Min Illumination:	0.2 LUX @ F2.0
Electronic Shutter:	1/60s - 1/100,000s, ON/OFF Switch-able
Iris Control:	Built-in DC Drive Iris Control
Flickerless Mode:	1/60s ON/OFF switchable
Gain Control:	High/Low switchable
Auto White Balance:	Color Temperature: 2500K-9500K
Back Light Comp.:	ON/OFF switchable
Gamma Characteristic:	0.45
Camera Lens:	Vari-Focal with DC Drive Iris Lens
Focal Length & App. Ratio:	3.3mm-12mm, F1.6-360
Angle Field of View:	Wide: 78.9°x58.3°, Tele: 35.4°x26.5°
Sync. System:	Internal, Negative sync.
Power Supply:	12VDC
Power Consumption:	230 mA
Video Output:	1 Vp-p @ 75 ohms
Operating Temp:	-10°C to 50°C (14°F to 122°F)

Specifications subject to change without notice.

CHANNEL VISION Limited Warranty

Channel Vision Technology will repair or replace any defect in material or workmanship which occurs during normal use of this product with new or rebuilt parts, free of charge in the USA, for two years from the date of original purchase. This is a no hassle warranty with no mail in warranty card needed. This warranty does not cover damages in shipment, failures caused by other products not supplied by Channel Vision Technology, or failures due to accident, misuse, abuse, or alteration of the equipment. This warranty is extended only to the original purchaser, and a purchase receipt, invoice, or other proof of original purchase date will be required before warranty repairs are provided.

Mail in service can be obtained during the warranty period by calling (800) 840-0288 toll free. A Return Authorization number must be obtained in advance and can be marked on the outside of the shipping carton.

This warranty gives you specific legal rights and you may have other rights (which vary from state to state). If a problem with this product develops during or after the warranty period, please contact Channel Vision Technology, your dealer or any factory-authorized service center.



6500 Color Box Camera

BY  CHANNEL VISION™

©2006 CHANNEL VISION TECHNOLOGY

Model 6500

The **6500** is a color box camera. Its vari-focal lens provides a wide range of adjustment allowing the system installer to achieve the best possible view. Typical applications included factories, retail stores, warehouses, and other commercial buildings.

Features:

- High quality 1/3" Sony Super HAD CCD sensor
- Vari-focal lens
- Built-in anti-aliasing filter and IR-cut optical filter
- Digital Signal Processor (DSP) chip-set provides image control
- High sensitivity, low smear, high anti-blooming and high S/N ratio
- Automatic Gain Control (AGC) and Auto White Balance (AWB)

Box Camera Side View

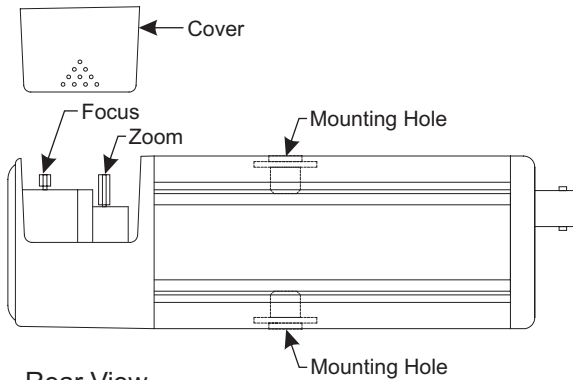

Rear View

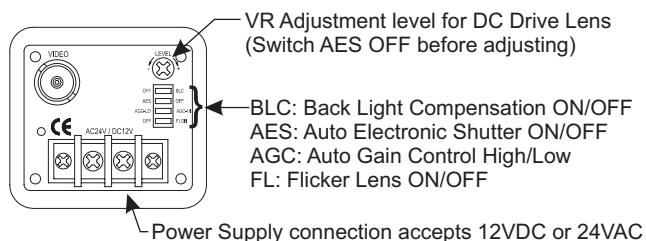

Power Supply

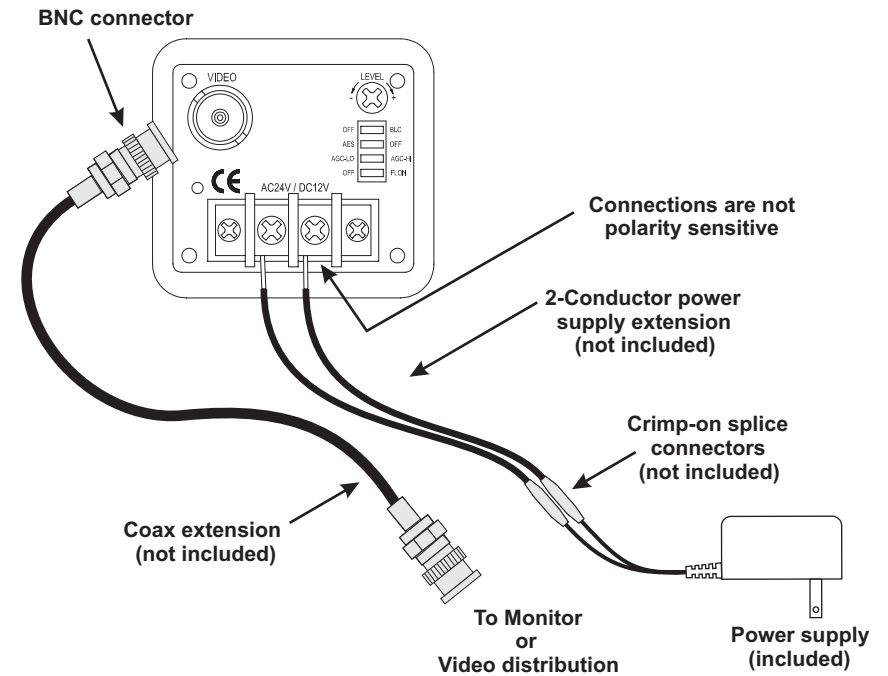
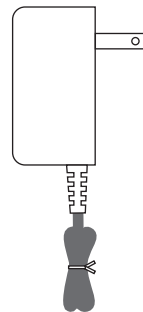

Installation:

- Mount camera in the desired location.
- Attach the camera's video output to a coax extension that is long enough to reach your monitor or video distribution equipment.
- If necessary, extend the power supply leads so they are long enough to reach the camera.
- Point the camera at the desired location and adjust the view with the zoom and focus controls. You may also make electronic adjustments using the dip switches.