

10 Year Limited Warranty

Channel Vision Technology will repair or replace any defect in material or workmanship which occurs during normal use of this product with new or rebuilt parts, free of charge in the USA, for ten years from the date of original purchase. This is a no hassle warranty with no mail in warranty card needed. This warranty does not cover damages in shipment, failures caused by other products not supplied by Channel Vision Technology, or failures due to accident, misuse, abuse, or alteration of the equipment. This warranty is extended only to the original purchaser, and a purchase receipt, invoice, or other proof of original purchase date will be required before warranty repairs are provided.

Mail in service can be obtained during the warranty period by calling (800) 840-0288 toll free. A Return Authorization number must be obtained in advance and can be marked on the outside of the shipping carton.

This warranty gives you specific legal rights and you may have other rights (which vary from state to state). If a problem with this product develops during or after the warranty period, please contact Channel Vision Technology, your dealer or any factory-authorized service center.

Channel Vision products are not intended for use in medical, lifesaving, life sustaining or critical environment applications. Channel Vision customers using or selling Channel Vision products for use in such applications do so at their own risk and agree to fully indemnify Channel Vision for any damages resulting from such improper use or sale.

Specifications:

110 Connectors:	8
RJ-45:	8
RJ-45 Configuration:	T568B
Compliant Standards:	10/100/1000BASE-T
Wire type:	UTP Category 5, 5e or 6
Dimensions:	3.0" L x 6.38" W x 1.75" D

Specifications subject to change without notice.

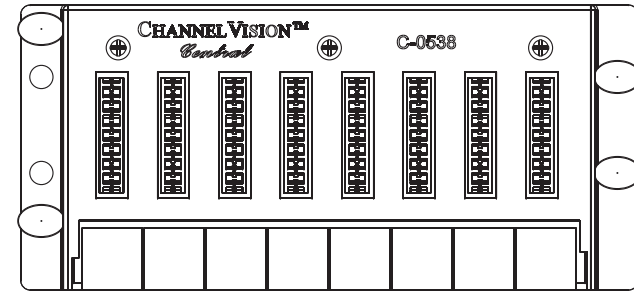

C-0538 8-port CAT6 Data Patch Panel

Model C-0538

The **C-0538** 8-port CAT6 Data Patch Panel is a structured wiring patch module for high-speed data networks. Compliant with 1000BASE-T specifications, the C-0538 will allow easy connectivity and flexibility without creating a transmission bottleneck. Backward compatibility with CAT5 wire makes this data patch module the perfect choice for any modern data network.

Features:

- Eight 110 punch down and eight RJ-45 connections
- Ideal for high-bandwidth video streaming applications
- Compatible with Category 5, 5e, and 6 wiring
- Easy installation

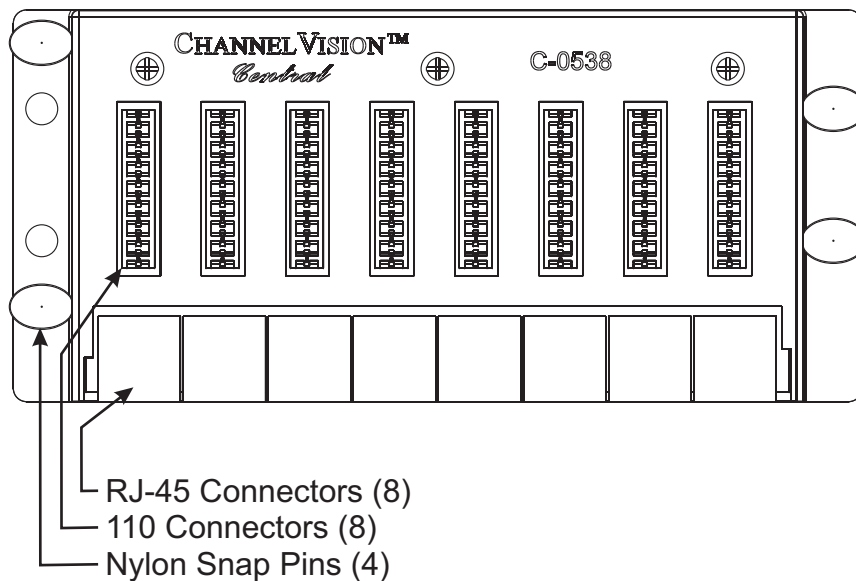

Installation Diagram

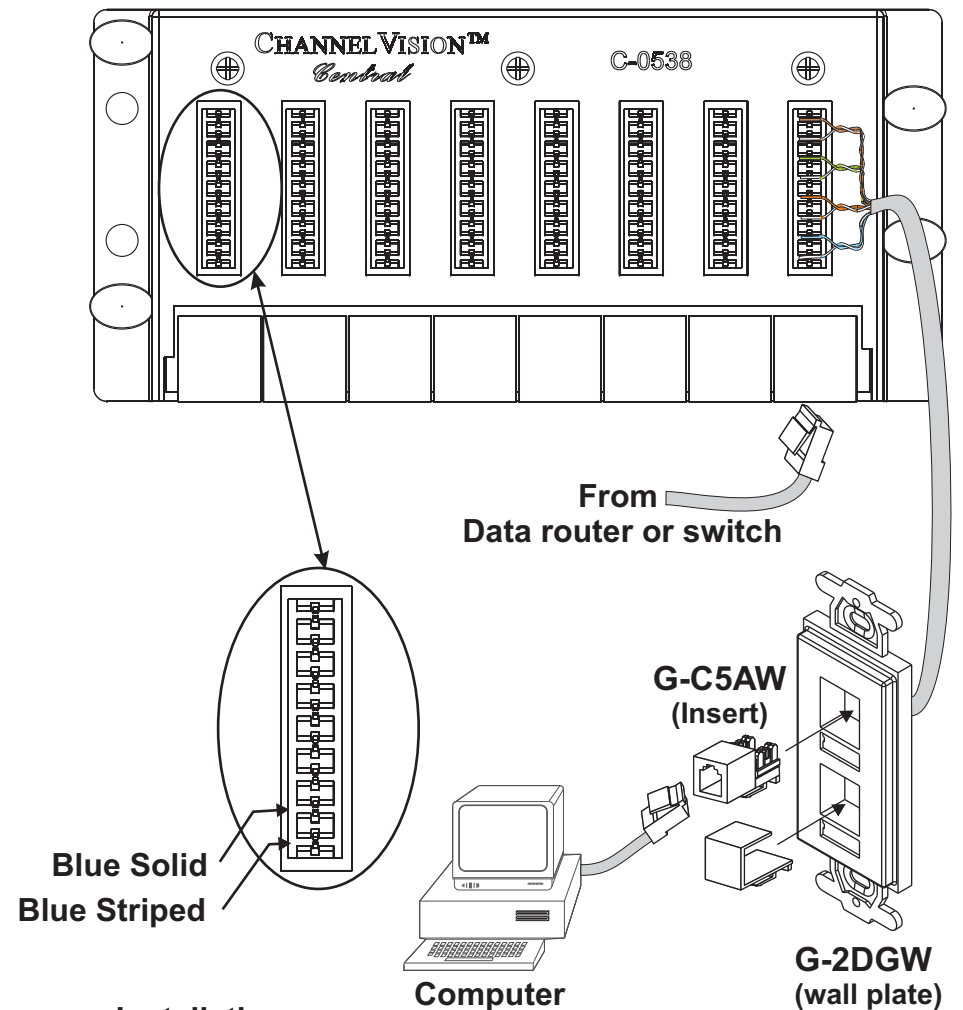

Installation:

- Use RJ-45 jumper cables to connect your data router or switch to the C-0538.
- Punch down as many as 8 CAT6 data lines on the 110 punch down connectors.
- Connect the data wall plates in each room (see diagram).
- Connect computer(s) to wall plate(s).