

## 10 Year Limited Warranty

Channel Vision Technology will repair or replace any defect in material or workmanship which occurs during normal use of this product with new or rebuilt parts, free of charge in the USA, for ten years from the date of original purchase. This is a no hassle warranty with no mail in warranty card needed. This warranty does not cover damages in shipment, failures caused by other products not supplied by Channel Vision Technology, or failures due to accident, misuse, abuse, or alteration of the equipment. This warranty is extended only to the original purchaser, and a purchase receipt, invoice, or other proof of original purchase date will be required before warranty repairs are provided.

Mail in service can be obtained during the warranty period by calling (800) 840-0288 toll free. A Return Authorization number must be obtained in advance and can be marked on the outside of the shipping carton.

This warranty gives you specific legal rights and you may have other rights (which vary from state to state). If a problem with this product develops during or after the warranty period, please contact Channel Vision Technology, your dealer or any factory-authorized service center.

Channel Vision products are not intended for use in medical, lifesaving, life sustaining or critical environment applications. Channel Vision customers using or selling Channel Vision products for use in such applications do so at their own risk and agree to fully indemnify Channel Vision for any damages resulting from such improper use or sale.

CHANNEL VISION™  
[www.channelvision.com](http://www.channelvision.com)

234 Fischer Avenue, Costa Mesa, California 92626 USA  
(714)424-6500 • (800)840-0288 • (714)424-6510 fax  
email: [techsupport@channelvision.com](mailto:techsupport@channelvision.com)

500-316 rev A

# INSTRUCTIONS

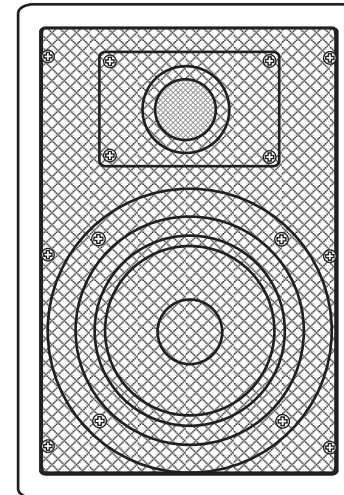

## IW603 6.5" IN-Wall Speaker

# Model IW603

Channel Vision's ARIA™ **IW603** 6.5" in-wall custom installation speakers feature high power handling capability providing true stereo quality sound and not simply background music. High quality materials ensure long life and great performance.

## Features:

- 6.5" in-wall loudspeaker
- Recommended power: 20W to 120W (peak)
- 1/2" voice coil
- Small perforated designer grill

## Installation:

- Use the provided template to mark and cut a hole in drywall away in the center of the stud bay.
- We recommend wiring with AWG 16 or larger, stranded wire.
- For proper phasing, both speakers must be wired alike. Connect red wires to red terminals on the speakers and to red or plus terminals on the amplifier.
- Install IW603 in the hole. Tighten the mounting screws. The mounting "dogs ears" will rotate outward and grip the drywall. **DO NOT OVER TIGHTEN** the screws. A battery operated drill on a "low clutch" setting is recommended.
- Place glue pads in the speaker's grill groove and install the grill.
- To control the volume of the speaker locally, use an impedance matching volume control, such as the Channel Vision VC-302.

## Specifications:

<b>Frequency range:</b>	60Hz - 20kHz
<b>Crossover:</b>	Electronic
<b>Sensitivity:</b>	89dB
<b>Power Handling:</b>	120 Watts peak
<b>Drivers:</b>	1/2" Compliance Polymer Tweeter Black PP Cone with Rubber Edge (woofer)
<b>Magnet:</b>	10-ounce magnet
<b>Impedance:</b>	8 ohms
<b>Finish:</b>	ABS plastic
<b>Dimensions:</b>	12.1 "H x 8.59" W x 3.7" D (Depth from surface of wall board) hole size: 10.74" x 7.32"

